



Thank you for purchasing KOSO plug-in indicator kit, before operating the unit, please read the instruction thoroughly and retain it for the future reference.

Notice

1. The lcd meter is apply for DC 12V.
2. For installation, please follow the steps described in manual. Any damage caused by wrong installation shall be imputed to the users.
3. To avoid the short circuit, please don't pull the wire when installing. Don't break or modify the wire terminal.
4. Do not disassemble or change any parts excluding the manual description.
5. The interior examination or maintenance should be executed by our professionals.

MARK MEANING:

NOTE You could get the installation details from the information behind the mark.

WARNING! Some processes must be followed to avoid damages to yourself or the public.

CAUTION! Some processes must be followed to avoid the damage to the vehicle.

1-1 Accessory

1 Plug in indicator light X1



2 Indicator light symbol X17



NOTE Please contact the local distributor if the items you open are not the same, with the above-listed one.

1-2 Option accessories

1 DB-02 METER



1 DB-02R METER



NOTE Some of the option accessories may not sell. For the details, please contact the local distributor.

2-1 Wiring installation instructions



2-2 Installation instructions

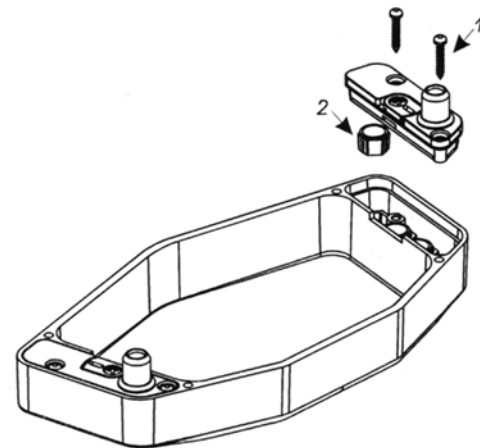

When installing, please follow the process.

1. Using the screw driver to loosen the M6 screw and take the back cap off.
2. Choosing the telltales what you need and insert it into telltales base.
3. Put the cover back and fasten the screw. (Both left and right side)

2-3 Installation instructions

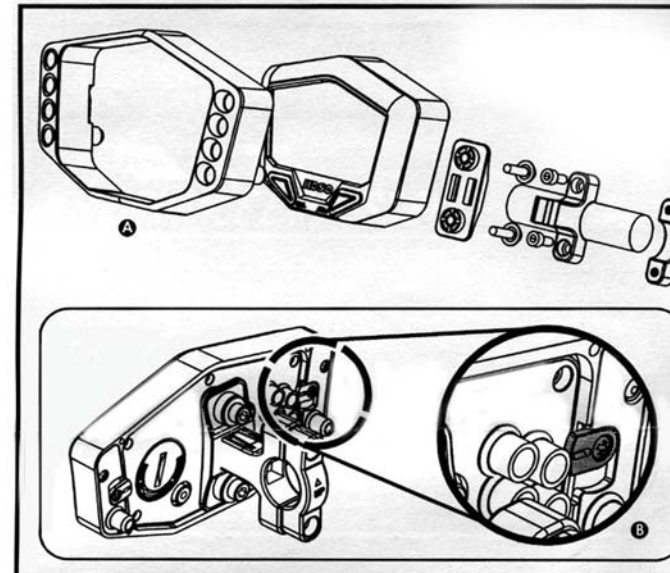

When installing, please follow the process.

Plug in indicator kit installation instruction.

- A Insert the indicator kit into the meter from upside of meter.
- B Turn indicator holder bracket 90 degree to fix the indicator kit with meter together.

3 Function, setting instruction

●Effective voltage	DC 12V	●Meter size (W X L X H)	141.5 X 72.4 X 18.4 mm
●Effective temperature range	-10~+60°C	●Meter weight	Around 68.5 g
●Meter standard	JIS D 0203 S2		

NOTE Design and specification are subject to change without notice!